



# 9611

## Switch & Distribution Unit

### KEY FEATURES

- Automatic Selection of Redundant Signal Inputs
- Twelve Signal Outputs
- Flexible Signal Configuration
- RS-232/422 Control Port
- Up To 32 Units on One Common Control Port

Symmetricom's 9611 Switch & Distribution Unit is an intelligent switching, monitoring and distribution system, packaged in a 1U rack mount chassis. It includes a dual input A-B switch that provides a powerful redundant capability.

The internal microprocessor can be set up to switch on a number of criteria (i.e., voltage level and period detection). Internally, the unit can be configured to direct selected signals to up to twelve independently buffered outputs. Each output can be set for internal monitoring of the output signals. In addition, each output system can be set up as a signal monitor. Any single-ended type signal can be connected to any output line and that line can be configured to simply monitor the signal. The input signal can be connected to any output buffer for additional distribution of the input signal.

The internal microprocessor is controlled, configured and monitored by means of an RS-232 input/output port. Switch status as well as output status is reported on the front panel for immediate feedback of information to the operator as well as via the RS-232 port. A second connector on the rear panel allows up to thirty-two units to be daisy-chained and controlled via a single serial port on the computer.

This universal and highly versatile instrument is unequalled in the industry. No other low cost system offers these capabilities in a single product.



9611 Switch & Distribution Unit

## 9611 Specifications

### ELECTRICAL SPECIFICATIONS

- Output levels: 0-6 volts p-p, DC-10 MHz  
(3 volts p-p above 5 MHz)
- Output impedance: 10 $\Omega$ , 50 $\Omega$  or 600 $\Omega$   
(selectable)
- Input levels: 0-6 volts p-p, DC-10 MHz
- Input impedance: 50 $\Omega$  or 1K, selectable
- Time period selection  
Range: 300 ns to 100 seconds in decade steps
- Distortion: Total harmonic at 10MHz, 3 V P-P into 50 $\Omega$   
Less than 0.5% [-40 dB]  
Spurs less than 60 dBc above 1KHz
- Phase noise [-dBVrms/ $\pm$ Hz]: At 10MHz, 3 V P-P into 50 $\Omega$  when using channel  
A or B as input  
Less than 102 @ 1Hz  
Less than 125 @ 10Hz  
Less than 140 @ 100Hz  
Less than 145 @ 1KHz  
Less than 150 @ 10KHz  
Less than 160 @ 100KHz  
Spurs less than -120 dB @ 1KHz
- Crosstalk: Channel B into Channel A, less than 40dB at  
10MHz.
- Reverse isolation: Channel 1 through 12 to any other channels 1  
through 12, less than 60dB at 10MHz.
- Hum noise levels: Less than -70dB

### ENVIRONMENTAL & PHYSICAL SPECIFICATIONS

- Temperature  
Operating: 0°C to 50°C  
Non-operating: -40°C to +70°C
- Humidity (non-condensing)  
Operating: 10% to 90%  
Non-operating: 5% to 95%
- Altitude  
Operating: 0 to 25,000'  
Non-operating: 0 to 40,000'
- Power requirements  
AC input: 120 or 230 V AC, <10W
- Dimensions  
Height: 1U (~1.73") (4.39 cm)  
Width: 19" (48.26 cm)  
Depth: 13" (32.02 cm)
- Weight: ~7.5 lbs. (3.37 Kg)

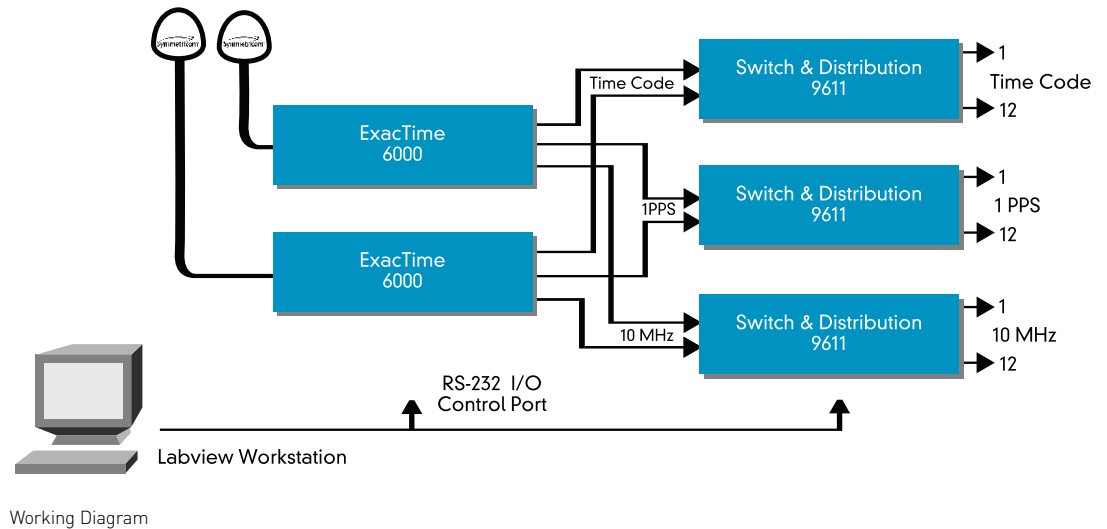

Rear View



**SYMMETRICOM, INC.**  
2300 Orchard Parkway  
San Jose, California  
95131-1017  
tel: 408.433.0910  
fax: 408.428.7896  
info@symmetricom.com  
www.symmetricom.com